

# Superb— 5000 Series Economical Guard Patrol System

## System Components :



- 1.5000A Patrol Wand
- 2.5000T USB Downloader
- 3.1900AF5 iButtons
4. Software

## Introduction:

Superb 5000A Patrol wand is a classic rugged, portable electronic data collection unit. With a simple touch, and access information by touching iButton which has memory chip housed in small, water-resistant, stainless steel case. It works like electronic label through which the patrol wand is able to read the information and store the data. The Superb 5000A patrol wand is rugged durability and internal real-time clock make it ideal for applications such as guard tours, time & attendance monitoring, or incident report & meter reading etc...

## Economical 5000A Patrol Wand:

### Features:

Rugged durability, alloy case and metal contactor.  
 Classic exterior design, LED flash and sound prompt.  
 Internal real time clock.  
 3600 nos. records storage capacity.  
 Sabotage absorbent.  
 Completely water resistant.  
 Long battery life, 200000 continuous reads.  
 Easy operation.

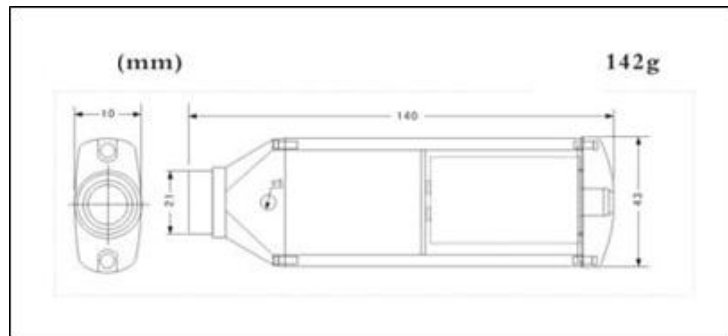

## Technical Information

Superb 5000A	
Physical	Extruded aluminum alloy case
Dimensions	138mmx43mmx23mm
Weight	143g
Operating Temperature	-45°to +85°C
Humidity	10% to 90% non-condensing
Memory	256Kb RAM
Storage Capacity	3600 button reads
Battery	One 9-volt alkaline, 200000 continuous reads
Communications	USB port downloader station
Prompt Means	LED flash and sound prompt

### Superb 1990AF5 iButton:



#### Features:

Touch Memory Buttons (iButton) are electronic memory chips contained in small water-resistant and stainless steel canister. All Touch Memory Buttons (TM card, iButton) contain a unique ID number that is unalterable and identifies each button. The Touch Memory Button's stainless steel container protects the memory chip and provides an electrical path for communication with the Superb 5000A guard patrol wand. The top of button is connected to the enclosed memory chip circuit, and the bottom and sides provide a signal ground. When you touch a button with the Superb 5000A guard patrol wand, an electrical connection is established data is transferred instantaneous. You can attach buttons to virtually anything by using permanent adhesive pads, mounting brackets, or key ring tabs.

### Superb 5000T Downloader:



#### Features:

Superb 5000T Downloader Station provides the communications link between the Superb 5000A guard patrol wand and the computer. With available communication speed of up to 19200 baud read, downloading a 5000A patrol wand to your computer takes only a few seconds.

#### Technical Information

Superb-5000T	
Dimensions	4.0 " x4.0 " x1.8 " (102mmx102mmx42mm)
Weight	7.4 ounces (210g)
Power Supplies	120v, 60Hz, 220v, 50Hz
Indicator Lights	Power, Transmit, and Receive
Connection Ports	Computer and Power

Specification is subject to change without prior notice.